

## Design and Development of Solar Power System For E-Rickshaw

Vimla Bhagat<sup>1</sup>, Harish Bijewar<sup>2</sup>, Praful Derkar<sup>3</sup>, Prof. Rahul Waghmare

*Dept. of Mechanical Engineering, Jhulelal Institute of Technology, Nagpur  
Asst. Professor, Mech. Dept., Jhulelal Institute of Technology, Nagpur*

**Abstract:** In order to achieve the sustainable environment for all the living beings from the pollution caused by the combustion of petrol and diesel in automobiles solar power should be used for the running of these vehicles. An electric rickshaw fitted with a solar panel and which run up to 40km per charge has a potential to replace the petrol consuming public transport vehicles. At our staggering consumption levels the worlds petroleum reserves will be exhausted in the next 30 to 40 years. Also the petroleum powered transportation network is responsible for a large amount of the hazardous emissions causing global warming and air pollution problems worldwide. Hence an alternative fuel should be used and solar energy is the cheapest and freely available sustainable energy which is captured by silicon plates fitted at the top of auto rickshaw for the sustainable energy future.

**Keywords:** Solar rickshaw, Sustainable energy, Global warming, Air pollution, Hazardous emission.

### I. Introduction

India's roads are becoming more congested each year with not only cars and buses, but especially two- and three-wheelers. India is home to over 2.5 million auto rickshaws (three-wheelers), and this number is growing, with over 250,000 new rickshaws sold in India each year. Research has shown that motorization is increasing even more rapidly than urbanization, and the increased traffic worsens India's already prevalent pollution problem.

Many major cities are beginning to prohibit the use of petrol powered rickshaws, and due to this, major rickshaw manufacturers such as Bajaj Auto are seeing increases in sales of alternate fuel powered rickshaws, such as Compressed Natural Gas (CNG) and Liquefied Petroleum Gas (LPG) models. With the factors of pollution and increased traffic in mind, the best way to revamp the rickshaw is to develop a more efficient design that will be powered by a non-polluting energy source, which can be achieved with an electric drive train since there are zero pollutants at the tailpipe.

A renewable source would make it a better solution compared to the current alternative fuel-powered rickshaws. One way to do this is to use an energy system that can take advantage of several sources of renewable energy—namely, an electric system. The electricity may be provided by solar, wind, hydro, or other renewable sources. Rickshaws are great candidates for electrification due to their low speeds and a relatively little distance covered in a day. In this paper, a solar/battery electric auto rickshaw is presented. The modeled vehicle is close to the desired performance of 80 KM of daily range and it is meeting the drive cycle.

### Description of e-Rickshaw

E-Rickshaws have been becoming a mode of transport in semi urban areas for first & last-mile connectivity to bus stands, metro stations, etc. since 2010 as an alternative to petrol/diesel/CNG auto-rickshaws & pulled rickshaws because of their low running cost and less human effort compared to pulled rickshaws. These are 3-wheelers pulled by an electric motor ranging from 650-1400 Watts for a route of less than 5 km.

### Manufacturing, Design, Construction & Working Principle

Manufacturing of e-Rickshaws are done on customization of drivers in an unorganized sector and final cost ranges from Rs. 1,00,000 to 1,50,000. These are mostly manufactured in China & India and only a few other countries. E-Rickshaws are built on M.S. (Mild Steel) Chassis which consists of 3-wheel with a differential at rear wheels. Body design varies from passenger segment to load carriers. These are designed to carry a weight ranging from 400Kg to 500Kg according to their type of operation. The working of e-Rickshaw is based on DC motor, battery & suspension system different from conventional auto rickshaws.

It uses a Brush Less DC motor ranging from 650- 1400 Watts with a differential mechanism at rear wheels. The electrical system used in Indian cities is 48V. Some variants made in fiber are also in use due to their strength

and durability, resulting in low maintenance. It consists of the controller unit. The battery used is mostly Lead acid/Li-ion battery with a life of 6-12 months. Deep discharge/cyclebatteries designed for EVs are mostly used.

### Major Parts and Components

**Electric Motor:** Brush Less Direct Current (BLDC) type 650- 1400W &48V (Input) motor is used. It is controlled via an electronic controller.

**Electronic Motor Controller:** The controller includes a manual or automatic switch turning the motor on/off, selecting forward or reverse motion, selecting and regulating speed, regulating or limiting torque and protecting against overloads. It is connected to battery pack and controller feeds the input to the motor, lamp, AC/DC converter and Speedometer/Indicator.

**Battery:** Set of four 12V deep cycle lead acid/Li-ion batteries are used since the required voltage is 48V. These batteries are connected in series to the controller unit.

**Differential:** Chinese manufactured differential is used in e- Rickshaws which is connected to the electric motor and rear wheels.

**Front Shock Absorbers:** Helical Spring with dampener with hydraulic telescopic shock absorbers is used.

**Rear Suspension:** Leaf spring carriage spring with rear shocker

**Brakes:** Drum brakes, actuated internally, expanding shoe type are used. Brakes are mounted on the chassis (Pedal brakes), so on pressing the pedal, the brake will engage stopping the rear wheels.

**Speedometer/Indicator:** Speedometer generally used have analog dials. The one the left side indicates vehicle speed and one on the right side indicate battery charge level. It is connected to the controller unit.

**Steering:** Handle bar type steering is used.

## II. Component Description

### Solar Panel:

In this project we use four solar panels of 100W each. The solar panel is being manufactured by a company named "MF ENERGY". The specification of solar panel is as below:

SR.NO.	CHARACTERISTIC	RATED OUTPUT
1	Maximum power	100Wp
2	Open circuit voltage	22.30V
3	Short circuit current	6.30 A
4	Voltage at maximum power	18.20 V
5	Current at maximum power	5.51 A
6	Tolerance	+/- 3%
7	Series fuse rating	6 A
8	Application class ratings	Class A
9	Fire rating	Class C

### Solar Charge Controller:

A solar charge controller manages the power going into the battery bank from the solar array. It ensures that the deep cycle batteries are not overcharged during the day, and that the power doesn't run backwards to the solar panels overnight and drain the batteries. Some charge controllers are available with additional capabilities like lighting and load control, but managing the power is its primary job.

A solar charge controller is available in two different technologies, PWM and MPPT. How they perform in a system is very different from each other. An MPPT charge controller is more expensive than a PWM charge controller, and it is often worth it to pay the extra money.

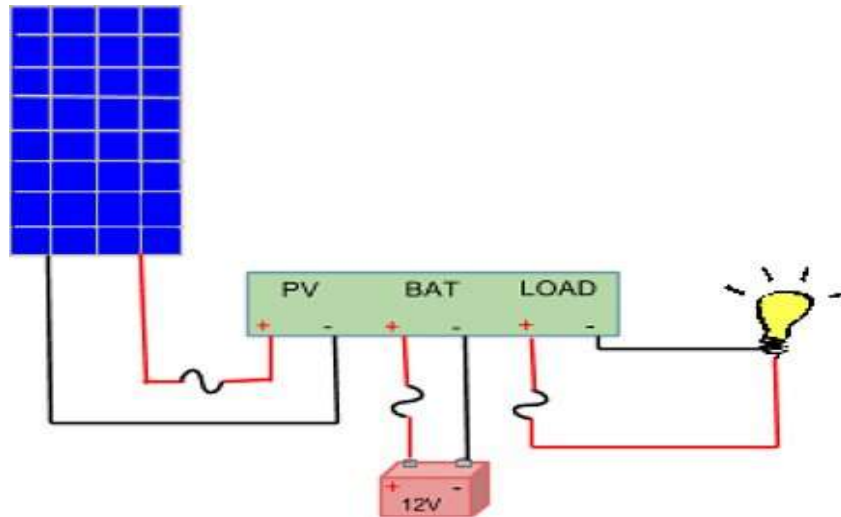

### III. Working Mechanism

In this project we used four solar panel of 100W each. We provide  $21^{\circ}$  angles to each panel for maximum utilization of solar radiation. A mechanism of our project is shown in picture below.



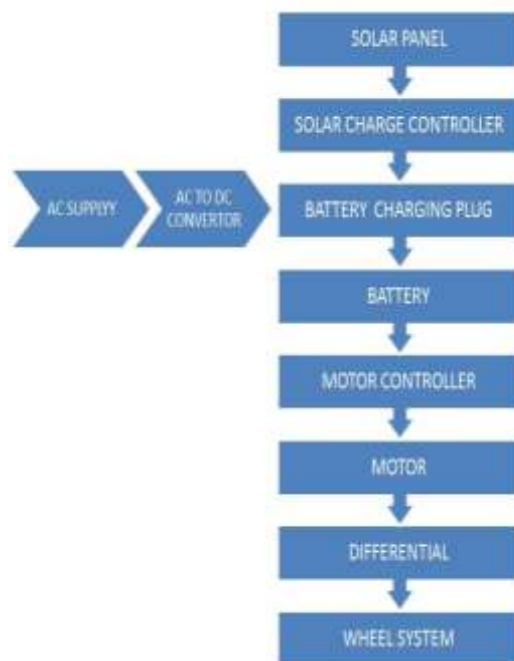

BLOCK DIAGRAM OF WORKING

#### IV. Conclusion

The rickshaw plays a fundamental role in the Indian auto industry. We have explored that role and the role of alternative technologies in this industry, including renewable energy technologies. Research shows that there is adequate support and a great premise for technologies incorporating renewable energies.

Thus, simulations have been performed on the supporting infrastructure for an electric rickshaw and on the rickshaw itself. Additionally, a prototype has been built and tested and has validated the rickshaw model electric rickshaw with solar assist can achieve a feasible range of operation during a single charge. One rickshaw design considered as a case study here can go about 90 km. With appropriate control and solar energy input, it is possible to achieve the average daily range of the vehicle, which makes the case for the technology of a plug-in electric rickshaw with solar assist. From this point, efforts should partly be focused on increasing the efficiency of the electrical system and all mechanical components. Future experimental verification should focus on the Sun-Tracking solar panel mounted on the prototype.

#### References

- [1]. S. Lukic, P. Mulhall, and A. Emadi "Energy autonomous solar/battery auto rickshaw," Journal of Asian Electric Vehicles, Dec. 2008.
- [2]. "Breaking the trend: visioning and backcasting for transport in India and Delhi," Halcrow Group Ltd., May 2008, Retrieved Feb. 17th, 2009 from <http://www.adb.org/Documents/Produced-Under-TA/39578/39578-REG-DPTA.pdf>
- [3]. P. Mulhall, M. Naviwala, S. M. Lukic, J. Braband, and A. Emadi "Entrepreneurial projects program at Illinois Institute of Technology:solar/battery hybrid three-wheel auto rickshaw for India," in Proc.2007 IEEE Vehicle Power and Propulsion Conference, Arlington,TX, Sep. 2007.
- [4]. "Bajaj Auto Ltd. Annual Report, 2007-08," Bajaj Auto Ltd., Retrieved Jan. 31st, 2009 from [http://www.bajajauto.com/1024/download/BAJAJ\\_Auto.pdf](http://www.bajajauto.com/1024/download/BAJAJ_Auto.pdf)
- [5]. Dr. J.P. Kesari and Rajat Sharma 2015.Design and Development of Solar Electric Vehicles at Delhi Technological University. IJISSET - International Journal of Innovative Science, Engineering & Technology, Vol. 2 Issue 3, March 2015. <http://ijiset.com/articlesv2/articlesv2s3.html> ISSN 2348 – 7968
- [6]. A. P. Agalgaonkar, C. V. Dobariya, M. G. Kanabar, S. A. Khaparde, and S. V. Kulkarni, "Optimal sizing of distributed generators in microgrid," IEEE Power India Conference, June 2006
- [7]. S. M. Lukic, P. Mulhall, G. Choi, M. Naviwala, S. Nimmagadda, and A. Emadi, "Usage pattern development for three-wheel auto rickshaw taxis in India," in Proc. 2007 IEEE Vehicle Power and Propulsion Conference, Arlington, TX, Sep. 2007.
- [8]. Brouwer, A.S.; Kuramochi, T.; Van Den Broek, M.; Faaij, A. Fulfilling the electricity demand of electric vehicles in the long term future: An evaluation of centralized and decentralized power supply systems. Appl. Energy 2013, 107, 33–51. [CrossRef]
- [9]. Hannan, M.A.; Azidin, F.A.; Mohamed, A. Multi-sources model and control algorithm of an energy management system for light electric vehicles. Energy Convers.Manag. 2012, 62, 123–130. [CrossRef]
- [10]. Fiori, C.; Ahn, K.; Rakha, H.A. Power-based electric vehicle energy consumption model: Model development and validation. Appl. Energy 2016, 168, 257–268. [CrossRef]

- [11]. Baptista, P.; Duarte, G.; Goncalves, G.; Farias, T. Evaluation of low power electric vehicles in demanding urban conditions: An application to Lisbon. In Proceedings of the 2013 World Electric Vehicle Symposium and Exhibition (EVS27), Barcelona, Spain, 17–20 November 2013; pp. 1–10.
- [12]. Lukic, S.; Mulhall, P.; Emadi, A. Energy Autonomous Solar/battery Auto Rickshaw. *J. Asian Electr. Veh.* 2008, 6, 1135–1143. [CrossRef]
- [13]. Nunes, P.; Farias, T.; Brito, M.C. Day charging electric vehicles with excess solar electricity for a sustainable energy system. *Energy* 2015, 80, 263–274. [CrossRef]
- [14]. Solar Roof for Toyota Prius Plug-in—Autoblog. Available online: <http://www.autoblog.com/2017/02/28/panasonic-toyota-prius-roof-solar-panel/> (accessed on 24 April 2017).
- [15]. Ford C-MAX Solar Energi Concept. Available online: <https://media.ford.com/content/fordmedia/fna/us/en/news/2014/01/02/let-the-sun-in--ford-c-max-solar-energi-concept-goes-off-the-gri.html> (accessed on 24 April 2017).
- [16]. Lukic, S.M.; Mulhall, P.; Choi, G.; Naviwala, M.; Nimmagadda, S.; Emadi, A. Usage Pattern Development for Three-Wheel Auto Rickshaw Taxis in India. In Proceedings of the 2007 IEEE Vehicle Power and Propulsion Conference, Arlington, TX, USA, 9–12 September 2007; pp. 610–616.
- [17]. Mulhall, P.; Emadi, A. Comprehensive simulations and comparative analysis of the electric propulsion motor for a solar/battery electric auto rickshaw three-wheeler. In Proceedings of the 2009 35th Annual Conference of IEEE Industrial Electronics, Porto, Portugal, 3–5 November 2009; pp. 3785–3790.
- [18]. Prabhu, V.N.; Manigandan, N. Design and Fabrication of Solar Transport Vehicle. *OSR J. Mech. Civ. Eng.* 2014, 11, 14–19.
- [19]. Mani, A.; Kreutzmann, P. Design and performance analysis of a hybrid solar tricycle for a sustainable local commute. *Renew. Sustain. Energy Rev.* 2015, 41, 473–482.